

# CONTÊNERES AÉREOS

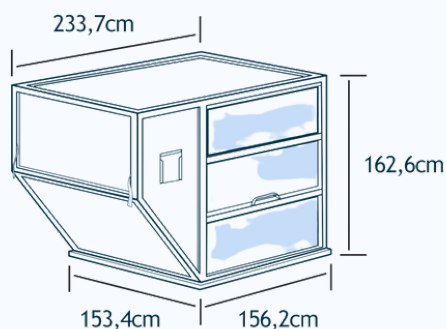

## ESPECIFICAÇÕES GERAIS

### LD-1



IATA ULD Code	AKC Contoured Container
<b>Também conhecido como</b>	<b>AVC, AVD, AVK, AVJ AND forkable AVY</b>
Adequado para	747, 767, 777, 787 e MD-11
Abertura de Portas	147cm de largura x 155cm de altura
Peso Bruto Máximo	1.588kg
Tara	70 a 170kg
Volume Interno	5m <sup>3</sup>

### LD-2

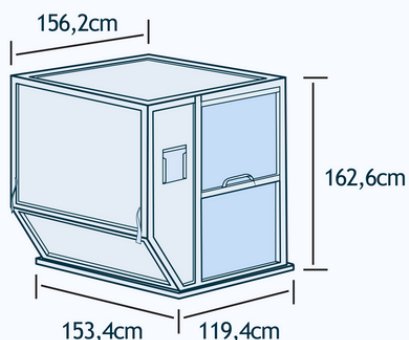

IATA ULD Code	DPE Contoured Container
<b>Também conhecido como</b>	<b>APA, DPA e forkable DPN</b>
Adequado para	747, 767, 777 e 787
Abertura de Portas	112cm de largura x 152cm de altura
Peso Bruto Máximo	1.225kg
Tara	92kg
Volume Interno	m <sup>3</sup>

### LD-3

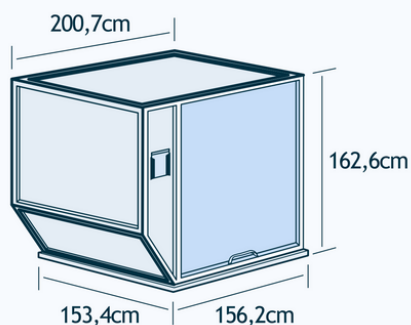

IATA ULD Code	AKC Contoured Container
<b>Também conhecido como</b>	<b>AKE, AVA, AVB, AVC, AVK, DVA, DVE, DVP, XKS, XKG and forkable AKN, AVN, DKN, DVN and XKN</b>
Adequado para	747, 767, 777, 787, DC-10 e MD-11
Abertura de Portas	147cm de largura x 155cm de altura
Peso Bruto Máximo	1.588kg
Tara	82kg
Volume Interno	4,5m <sup>3</sup>

### LD-3 REEFER

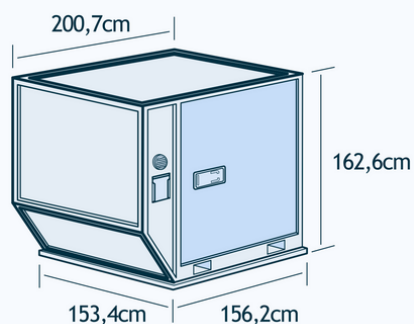

IATA ULD Code	RKN Contoured Container
<b>Também conhecido como</b>	<b>RVN</b>
Adequado para	747, 767, 777, 787, DC-10 e MD-11
Abertura de Portas	137cm de largura x 140cm de altura
Peso Bruto Máximo	1.588kg
Tara	210kg
Volume Interno	4,5m <sup>3</sup>

# CONTÊINERES AÉREOS



## ESPECIFICAÇÕES GERAIS

### LD-4

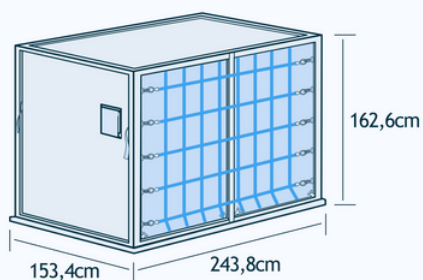

IATA ULD Code	ALP Rectangular Container
Também conhecido como	ALD, AWD, AWZ, DLP e forkable ALB, ALC, AWB e AWC
Adequado para	767, 777 e 787
Abertura de Portas	234cm de largura x 155cm de altura
Peso Bruto Máximo	2.449kg
Tara	120kg
Volume Interno	5,7m <sup>3</sup>

### LD-6

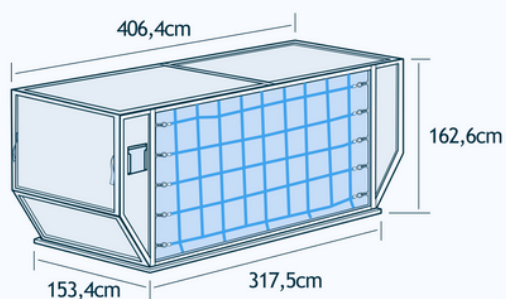

IATA ULD Code	ALF Contoured Container
Também conhecido como	AWA, AWF e forkable AWC
Adequado para	747, 777, 787, DC-10 e MD-11
Abertura de Portas	305cm de largura x 152cm de altura
Peso Bruto Máximo	3.175kg
Tara	230kg
Volume Interno	9,1m <sup>3</sup>

### HALF PALLET PNA

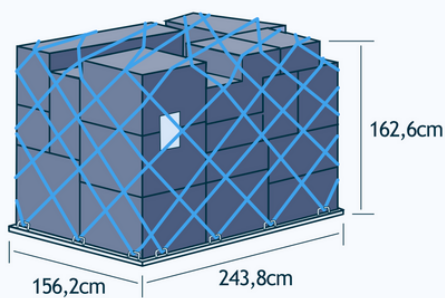

IATA ULD Code	PNA 767 Half Pallet With Net
Também conhecido como	PQP, FQF e PPC
Adequado para	767, 787
Peso Bruto Máximo	2.449kg
Tara	83kg
Volume Interno	5,5m <sup>3</sup>

### HALF PALLET PLA

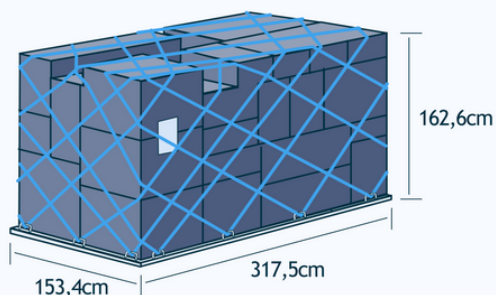

IATA ULD Code	PLA Half Pallet With Net
Também conhecido como	PLB, FLA, P9A, P9B, P9P, P9R e P9S
Adequado para	747, 777, 787, 707F, 727F e 737F
Peso Bruto Máximo	3.175kg
Tara	91kg
Volume Interno	7,1m <sup>3</sup>



### LD-7 - FLAT PALLET

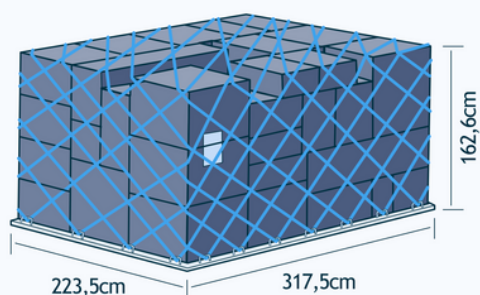

IATA ULD Code	P1P Flat Pallet With Net
Também conhecido como	PAA, PAG, PAJ, PAP, PAX, P1A, P1C, P1D e P1G
Adequado para	707F, 727F, 737F, 757F, DC8F e DC9F
Peso Bruto Máximo	4.626kg
Tara	105kg
Volume Interno	10,5m <sup>3</sup>

### LD-7 - FOLDING WINGS

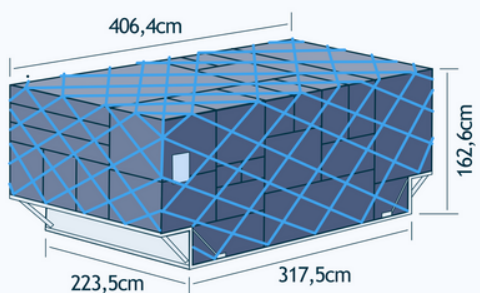

IATA ULD Code	PAD P1P Pallet With Folding Wings and Net
Também conhecido como	PAX e P1X
Adequado para	747, 777, 787, DC-10 e MD-11
Peso Bruto Máximo	5.000kg
Tara	105kg
Volume Interno	10,5m <sup>3</sup>

### LD-7 - FIXED-ANGLE

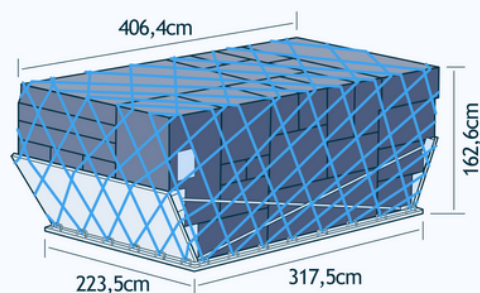

IATA ULD Code	XAW P1P Pallet With Fixed-angle Wings and Net
Adequado para	747, 777, 787, DC-10 e MD-11
Peso Bruto Máximo	5.000kg
Tara	170kg
Volume Interno	14,0m <sup>3</sup>

### LD-8

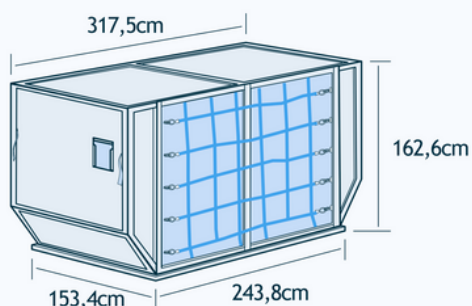

IATA ULD Code	DQF
Também conhecido como	ALE, ALN, DLE, DLF, DQP e MQP
Adequado para	767 e 787
Abertura de Portas	234cm de largura x 157cm de altura
Peso Bruto Máximo	2.450kg
Tara	127kg
Volume Interno	7,1m <sup>3</sup>



### LD-9

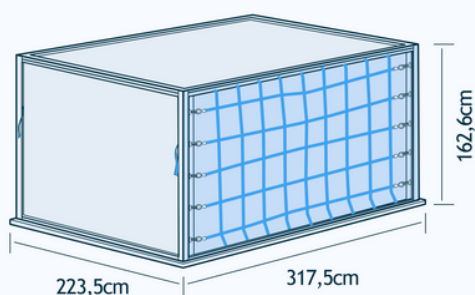

IATA ULD Code	AAP Enclosed Pallet on P1P Base
Adequado para	747, 767, 777, 787, DC-10 e MD-11
Abertura de Portas	300cm de largura x 147cm de altura
Peso Bruto Máximo	4.624kg
Tara	215Kg (porta em canvas), 270Kg (porta sólida)
Volume Interno	10,8m <sup>3</sup>

### LD-9 REEFER

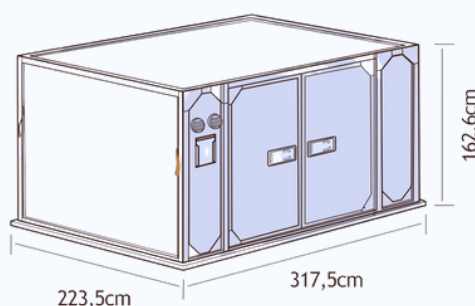

IATA ULD Code	RAP Cool Container on P1P Base
Adequado para	747, 767, 777, 787, DC-10 e MD-11
Abertura de Portas	216cm de largura x 147cm de altura
Peso Bruto Máximo	4.626kg
Tara	400Kg
Volume Interno	9,6m <sup>3</sup>

### LD-11

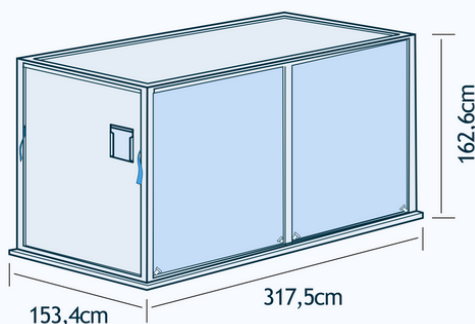

IATA ULD Code	ALP Rectangular Container
Também conhecido como	ALD, AW2, AWB, AWD, AWZ, DLP, DWB e MWB. Versão refrigerada: RWB, RWD e RWZ.
Adequado para	747, 767, 777, 787, DC-10 e MD-11
Abertura de Portas	305cm de largura x 155cm de altura
Peso Bruto Máximo	3.176kg
Tara	185kg
Volume Interno	7,4m <sup>3</sup>

### LD-26

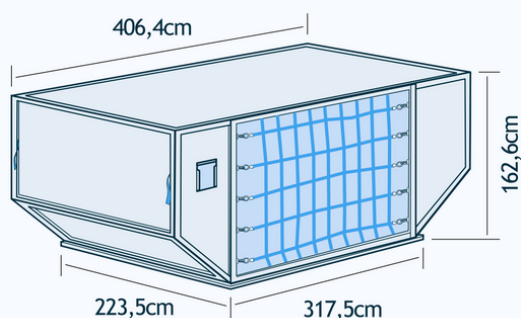

IATA ULD Code	AAF Contoured Container on P1P Base
Adequado para	747, 777, 787, DC-10 e MD11
Peso Bruto Máximo	6.033kg
Tara	250kg
Volume Interno	13,3m <sup>3</sup>

# CONTÊNERES AÉREOS

## ESPECIFICAÇÕES GERAIS



### LD-29

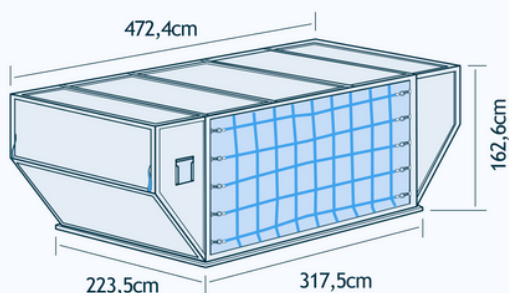

IATA ULD Code	AAU Countoured Container on P1P Base
Adequado para	747
Abertura de Portas	300cm de largura x 152cm de altura
Peso Bruto Máximo	6.033kg
Tara	265kg
Volume Interno	14,4m <sup>3</sup>

### LD-29 REEFER

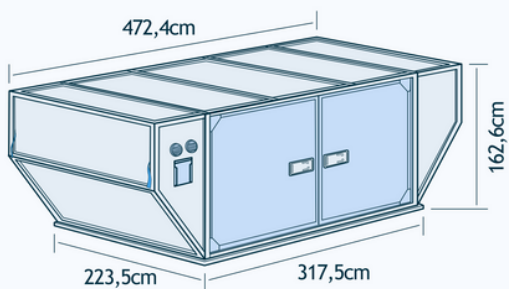

IATA ULD Code	RAU Contoured Cool Container on P1P Base
Adequado para	747
Abertura de Portas	300cm de largura x 152cm de altura
Peso Bruto Máximo	6.033kg
Tara	450kg
Volume Interno	11,1m <sup>3</sup>

### P6P PALLET

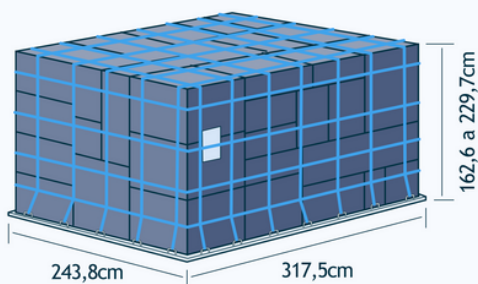

IATA ULD Code	P6P 10ft Flat Pallet With Net
Adequado para	747, 767, 777, 787, DC-10 e MD-11
Tara	185kg
Volume Interno	Altura 162,6cm > 11,5m <sup>3</sup> Altura 243,8cm > 17,0m <sup>3</sup> Altura 299,7cm > 21,2m <sup>3</sup>

### DEMI

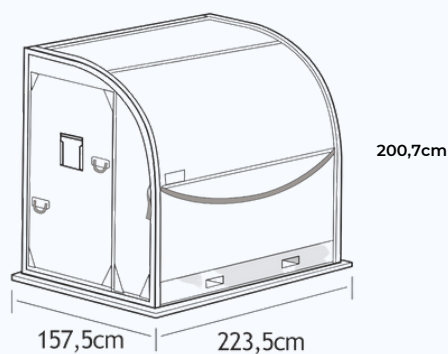

IATA ULD Code	AYY Contoured Container on Half Pallet Base
Adequado para	727F, 737F, 757F, 747F, 767F, 777F, DC-10F e MD-11F
Peso Bruto Máximo	3.016kg
Tara	80kg
Volume Interno	5,8m <sup>3</sup>